

## OFF-GRID SOLAR FIXTURE

# Display Light (SDL)

All-in-one design with solar panel, light engine and battery built into the fixture. No need for a power source, which eliminates the need for wiring and trenching. The perfect luminaire for signage, billboards, advertisements & more.

### FEATURES

- Completely off-grid, no need for wiring or trenching
- All-in-one design, the solar panel and battery are built right into the LED fixture
- 4 hours of 100% brightness, then 25% remainder of night with one charge
- Advanced new LiFePO4 replaceable battery will last at least 2000 charge cycles
- Perfect for signage, billboards, advertisements and walls
- Standard bracket included, optional clamp mount bracket available



### DIMENSIONS

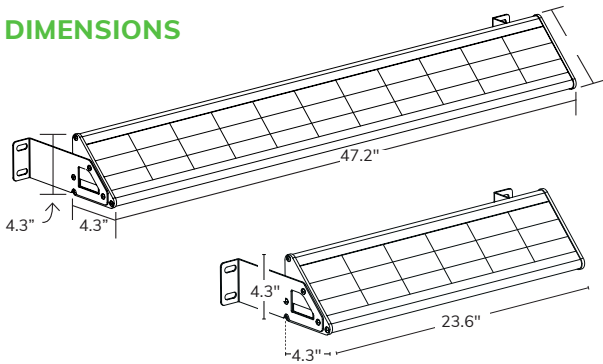

### SPECIFICATIONS

- **POWERED BY:** Solar
- **CHARGE TIME:** 8-9 hours
- **BATTERY LIFE:** upto 50 hours
- **BATTERY CHARGING TEMP:** 32°F to 113°F
- **OPERATING TEMP:** -4°F to 140°F
- **BEAM ANGLE:** 120°
- **INGRESS PROTECTION:** IP65
- **REPLACEABLE BATTERY:** Yes
- **RATED LIFE:** L70, >50,000
- **WARRANTY:** 3 years

MODEL	UPC	REPLACES	WATTAGE	LUMENS	CCT	WEIGHT
SDL-2FT-40K0-BK-G2	844006085193	70W HID		750 LM	4000K	11 lbs
SDL-4FT-40K-BK-G2	844006085926	150W HID	20W	2000 LM	4000K	

PART	DESCRIPTION
RP-SDL-BK-LB	7" CLAMP MOUNT BRACKET (2 PACK)

### CERTIFICATIONS

