



ROUND HIGH BAY

RB3 Industrial High Bay

The Illumus round RB3 high bay is a robust fixture designed for versatile applications. This high output luminaire produces up to 37,000 lumens and provides your work areas plenty of brightness. IP65 rated and NSF listed, this fixture can handle the harshest conditions including wet locations and food processing. This long life LED will last years while improving your light quality and saving you energy.

FEATURES

- Replaces 250 watt to 1,000 watt metal halide or high pressure sodium fixtures
- IP65 Rated for harsh conditions, damp and wet locations
- NSF Listed for food processing and production
- Powder coated cold-forged aluminium housing
- 6 foot mounting cord standard
- 12" safety cable provided
- Long life LED - (L70) rated over 100,000 hours
- UL listed for damp and wet locations
- Operating temperature: -40F to 122F
- Acrylic dome optional
- DLC 5.1 - rebate eligible

APPLICATIONS

- Food Processing
- Wet Locations
- Warehouses
- Gymnasiums
- Distribution Centers
- Manufacturing Plants

CERTIFICATIONS



SPECIFICATIONS

- **POWERED BY:** 120-277V
- **CCT:** 5000K
- **CRI:** 80+
- **WATTAGE (NOMINAL):** 100W, 200W or 240W
- **LUMENS:** 13,376 LM to 37,144 LM
- **EFFICACY:** 135-157 lumens per watt
- **OPERATING TEMP:** -40°F to 122°F
- **MOUNTING:** Hook with 6" power cord
- **IP RATING:** IP65
- **ENERGY SAVINGS:** 57-65%
- **WARRANTY:** 5 years / 50,000 hours
- **BRAND:** ILP Illumus

DIMENSIONS

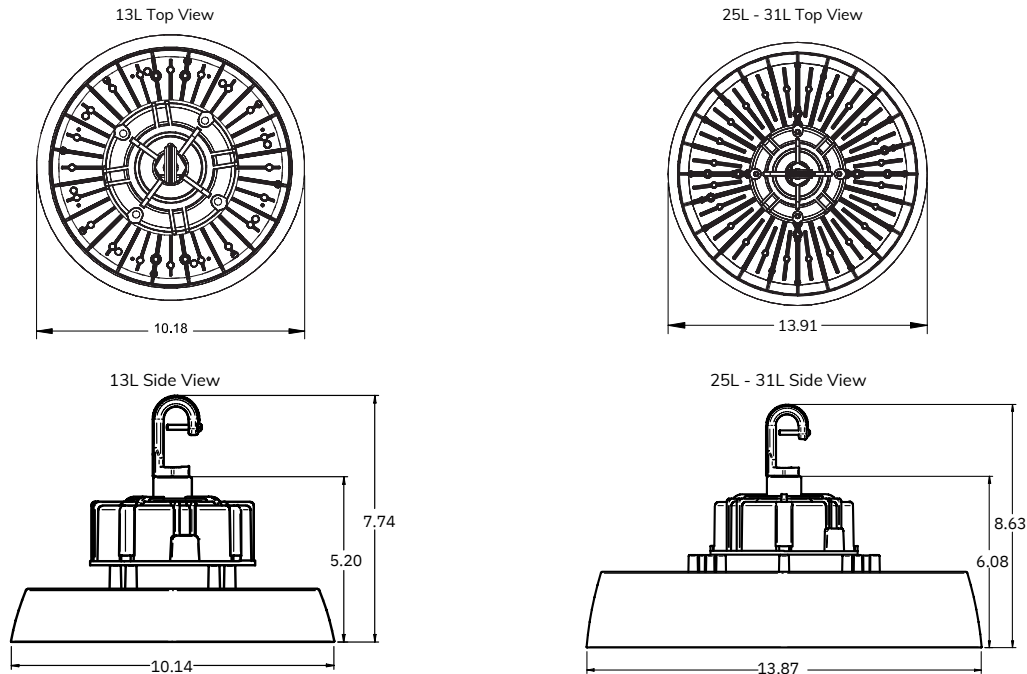

LUMINAIRE DATA	
Construction	Powder coated cold forged aluminum housing provides maximum rigidity and durability for the toughest of applications. Built-in cooling fins for maximum heat dissipation and high ambient temperatures. Standard 1/2" threaded hub for pendant mounting.
Optics	Standard with IK10 impact rated primary clear polycarbonate lens. Optional 22: frosted acrylic diffuser available.
Thermal	Ambient temperature range -40°F to 122°F (-40°C to 50°C)
Electrical	High performance LED light engine for high efficacy and long life. L70 > 100,000 hours. Standard 120-277 VAC, 1-10V dimmable (10%-100%) with optional 347-480 VAC step down transformer. 4kV built in surge protection. 6FT power cord and 6FT cord with dimming leads included.
Mounting	Single hook included. Other mounting options available.
Certifications	UL listed to US & Canadian safety standards. IP65 rated for wet location. NSF listed for food processing environments. DLC Premium Qualified.

ORDERING GUIDE

Model	Wattage	Lumens	CCT	LPW	Replaces
RB3-13L-U-50	98W	13,376 LM	5000K	136	250W HID
RB3-25L-U-50	193W	26,130 LM	5000K	135	400W HID
RB3-31L-U-50	237W	37,144 LM	5000K	157	750-1000W HID