

ADS Base Hook Mount

347/480V Step Down Transformer



Features

- Provides a mogul base to power EZ LED lamps
- Compatible with various cosmetic reflectors including prismatic, metal and cylinders.

Electrical

- 480V to 277V for USA
- 347V to 200V for Canada

	Amps @ Line Voltage (VAC)	
	347V	480V
140W	0.40A	0.29A
165W	0.48A	0.34A

Certifications

- UL and ULC
- IP52 / UL damp listed



Mechanical

• 2.88 kg / 6.35 lb5

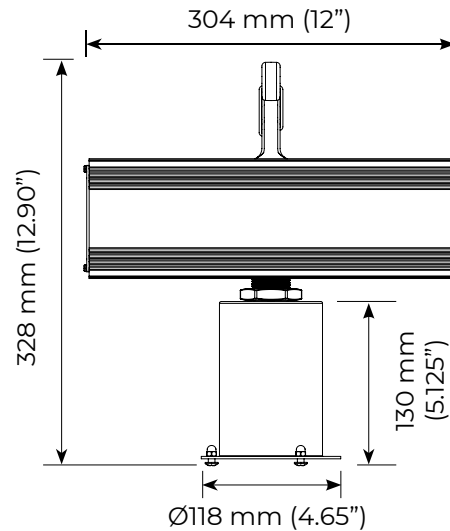

Ordering Information

Description	Part Code	Part Number	Quick Ship
EZ Base Step Down 347/480V E39 Socket Hook 2.0 M 165W NEMA L24-20P Plug	03740	ADS-E39-HKS-20-2420-0165-000-000	Yes

1. Unless otherwise specified, all values are typical at 25°C, 240VAC
 2. See limited warranty for details
 3. Specifications subject to change without notice

4. Not intended for use in environments containing airborne corrosive agents such as chemicals, solvents, or cutting fluids
 5. Weight of base without cable