

## HIGH BAY LED LAMP - BALLAST BYPASS

# OEO EZ LED Ultra Series, BB

This OEO EZ LED is a high output, ballast bypass LED lamp and runs directly on 120-277V line voltage. Bypassing the ballast further reduces energy and eliminates the need to check ballast compatibility. This lamp has no cooling fan thus widening the application range beyond previous versions - sawmills, refineries can now be included!

### FEATURES

- Simply bypass ballast to retrofit your current high bay fixtures
- Direct wired 120-277V
- No cooling fan; passive heat sink designed for dusty, dirty environments
- 67% energy savings
- Rated for over 60,000 hours
- Color temperature 5,000K, 70+ CRI
- Start-up: Instant on / instant re-strike
- Fast ROI payback
- No mercury or hazardous materials



### APPLICATIONS

- Manufacturing facilities
- Warehouses
- Machine & welding shops
- Paper converters
- Athletic facilities
- Sawmills & refineries

### CERTIFICATIONS



### SPECIFICATIONS

- **EFFICACY:** 133 lumens per watt
- **POWERED BY:** Wire direct 110-277V AC
- **ENERGY SAVINGS:** 67%
- **LIFESPAN:** 60,000 hrs
- **OPERATING TEMP:** -4°F to 131°F
- **FIXTURE TYPE:** OPEN / Indoor only
- **WEIGHT:** 2.8 lbs
- **BEAM ANGLE:** 90°
- **MOUNTING:** Vertical mogul base
- **DIMMABLE:** No
- **SENSORS:** Yes, compatible with occupancy sensors
- **WARRANTY:** 5 years

### NOTE:

\*\* Please inquire about a different OEO EZ LED product if you prefer to keep your ballasts.

# HIGH BAY LED LAMP OEO EZ LED - Ultra Series, Ballast Bypass



BEFORE

AFTER

## PRODUCT SPECIFICATIONS

PART NUMBER	REPLACES	LUMENS	WATTAGE	CCT	CRI
ULTRA HO-D-BB-P	400W	20,000	150W	5,000K	80+

## DIMENSIONS

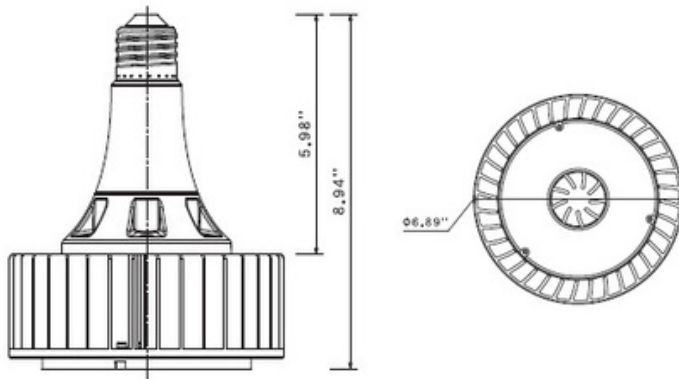

MODEL: EZ LED ULTRA HO-D-BB-P  
WEIGHT: 2.8 LBS

## PHOTOMETRY

