

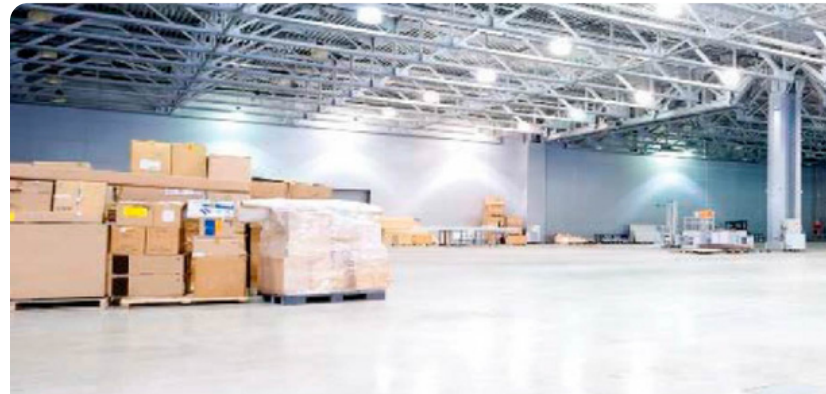

## HIGH BAY LED LAMP - HYBRID

# OEO EZ LED Super Hybrid (G2)

The OEO Super Hybrid G2 is a passively cooled industrial LED replacement for metal halide and high pressure sodium bulbs. Our special batwing optics are designed to eliminate glare and deliver previously wasted lumens to the target, resulting in 1.6x higher illumination on center and 2x higher at the edges, delivering better light levels at your work area. Versatile product is simultaneously ballast compatible (Type A) and line voltage 120-277v compatible (Type B).



### FEATURES

- Ballast compatible or ballast bypass
- Superior optical distribution provides improved light level, with more energy savings
- Reduce energy consumption by 50-75%
- Robust IP65 design for harsh conditions
- Passive heat sink for dusty, dirty environments
- Long life LED: 50,000 hrs; 5 year warranty
- Low glare design
- DLC 5.1 premium listed, rebate eligible
- Occupancy and daylight harvesting option
- Bluetooth control option

### APPLICATIONS

- Warehouse and manufacturing
- Machine and welding shops
- Paper and packaging converters
- Gymnasium and Sports Courts

### CERTIFICATIONS



**RoHS**

### SPECIFICATIONS

- **POWER:** 120-277v or HID Ballast
- **ENERGY SAVINGS:** 50-75%
- **BEAM ANGLE:** 100° Distribution
- **MOUNTING:** For Use in Vertical, Mogul Base E39, EX39
- **OPERATING TEMP:** -40°F to 122°F
- **CCT:** 5000K Standard, 4000K Optional
- **CRI:** 80
- **START UP:** Instant On/Off, Instant Re-strike
- **ENVIRONMENT:** IP65, dry and wet locations
- **CONTROLS:** Optional occupancy sensors, optional bluetooth controls
- **ADDITIONAL OPTIONS:** Uplight accessory, diffuser, prismatic dome, EZ base

# HIGH BAY LED BULB - HYBRID OEO EZ LED - Super Hybrid (G2)

## DELIVER MORE USABLE LIGHT WITH LESS LUMENS

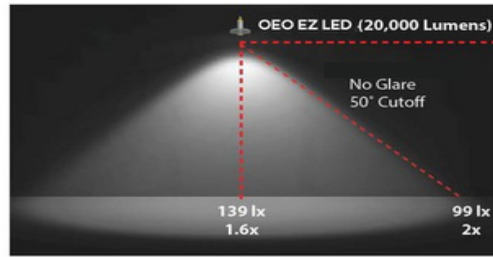
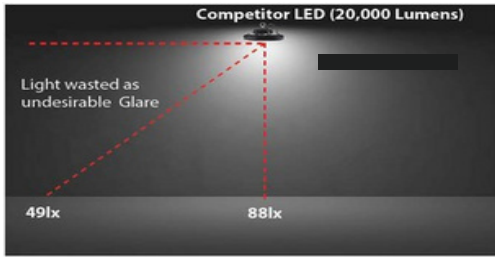

## DIMENSIONS

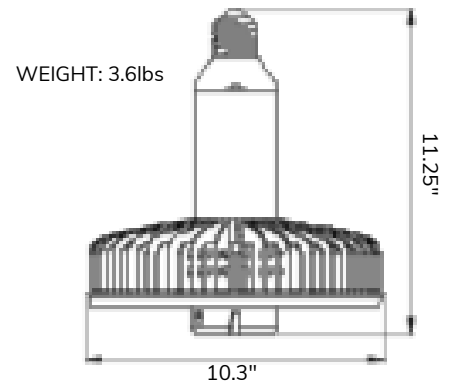

MODEL	WATTAGE	LUMENS	LUMENS / WATT	REPLACES	RATED
OEO EZ LED Super H-P-15K	105W	16010	152	250-400W HID	Enclosed / Open
OEO EZ LED Super H-P-20K	150W	20640	138	400W HID	Open
OEO EZ LED Super H-P-25K	165W	26130	158	750W HID	Open

## PHOTOMETRICS

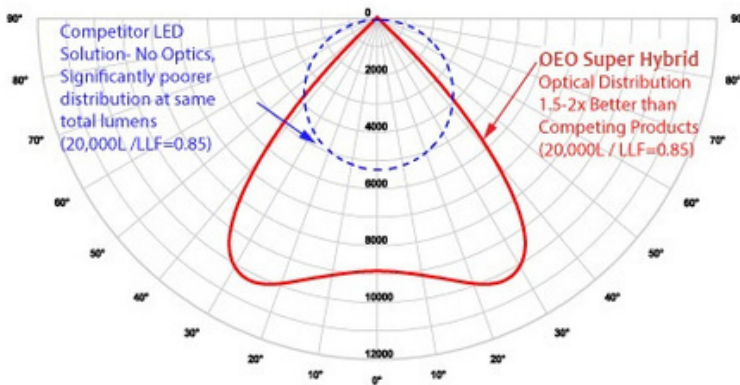

Polar Curve

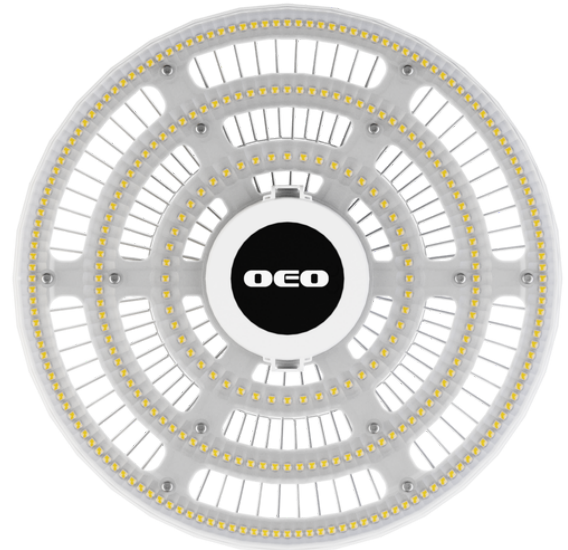

## ADDITIONAL OPTIONS

- Bluetooth network controls
- Occupancy / motion sensors
- Dimming, scheduling, grouping, zone controls
- Uplight accessory
- Mounting base
- Reflective dome (various finishes)

## SAFETY NOTES

- Turn off power when installing lamp
- Do NOT install in line voltage above 277v

# HIGH BAY LED BULB - HYBRID OEO EZ LED - Super Hybrid (G2)

## FOOTCANDLE MEASUREMENTS

		Fixture Height					
Super Hybrid 15kLm		25FT	30FT	35FT	40FT	45FT	50FT
Fixture Spacing	20FT	fc	41	41	40	40	39
	25FT	fc	27	27	27	26	26
	30FT	fc	19	19	19	19	18
	35FT	fc	14	14	14	14	13

		Fixture Height					
Super Hybrid 20kLm		25FT	30FT	35FT	40FT	45FT	50FT
Fixture Spacing	20FT	fc	54	53	53	52	52
	25FT	fc	35	35	35	34	34
	30FT	fc	25	25	25	24	24
	35FT	fc	18	18	18	18	18

		Fixture Height						
Super Hybrid 25kLm		20FT	25FT	30FT	35FT	40FT	45FT	50FT
Fixture Spacing	20FT	fc	72.9	72.9	72.8	72.6	72.3	71.9
	25FT	fc	46.5	46.4	46.4	46.3	46.1	45.6
	30FT	fc	32.2	32.5	32.6	32.7	32.7	32.5
	35FT	fc	23.3	23.5	23.6	23.6	23.6	23.4



YOU GET TWO OPERATING OPTIONS WITH ONE LED	
Ballast Compatible Mode	Ballast Bypass Mode
Plug-N-Play! Simple HID Direct Replacement	Line voltage must be between 110V-277V
Requires no re-wiring, no electrician	Requires simple ballast bypass
Use in operable MH/HPS Ballasts	Eliminate ballast maintenance

**\* THE OEO EZ LED SUPER HYBRID LAMP IS ALSO AVAILABLE IN A FIXTURE VERSION**

