



FEATURES

- 110+ LPW provides 40-60% in energy savings vs. fluorescent
- Field selectable color temperature - 3500K, 4000K, or 5000K
- Selectable wattage and lumen output - 3 steps, varied by models
- 2'x4', 2'x2', and 1'x4' configurations available for design flexibility
- Easy installation mounting into standard t-grid suspended ceiling systems
- Acrylic over-optics with polymer diffusing lens creates an extremely uniform visual aesthetic & provides even illumination on target
- Vitality LED technology reduces eye strain, increases alertness, reduces fatigue
- Integrated occupancy sensor and emergency battery backup systems available
- Surface mountig kits and cable suspension kits available
- Perfect blend of design, performance, and reliability
- DLC 5.1, rebate eligible

APPLICATIONS

- Commercial & Industrial
- Office, Healthcare, and Educational
- Hospitality
- Grocery & Retail
- Hallways
- Second and Third Shift Workspaces

LED OFFICE FIXTURE

LED Backlit Flat Panel

The Vitality series backlit flat panel contain patented LED technology engineered to boost alertness & reduce fatigue in indoor spaces where there is little natural sunlight. These **color selectable and wattage adjustable** LED panels provide you ultimate flexibility to meet your exact lighting needs. Offered in 2'x4', 2'x2', and 1'x4' standard sizes for design flexibility. Engineered to greatly reduce blue wavelengths commonly found in standard LEDs, these boost alertness, improve safety and productivity for your students, employees, and customers.



SPECIFICATIONS

- **POWERED BY:** 120-347V
- **CCT:** Adjustable | 3500K, 4000K or 5000K
- **WATTAGE:** Selectable
- **LUMENS:** Adjustable
- **CRI:** 80
- **EFFICACY:** 110 lumens per watt
- **OPERATING TEMP:** -13°F to 113°F
- **RATING:** 54,000 hours (L90)
- **REPLACES:** 2 to 4 lamp fluorescent T8 or T12 fixtures
- **CASE QUANTITY:** 2 fixtures
- **WARRANTY:** 10 years
- **BRAND:** Energetic Lighting

CERTIFICATIONS

**RoHS**

LED OFFICE FIXTURE LED Backlit Flat Panels

DIMENSIONS

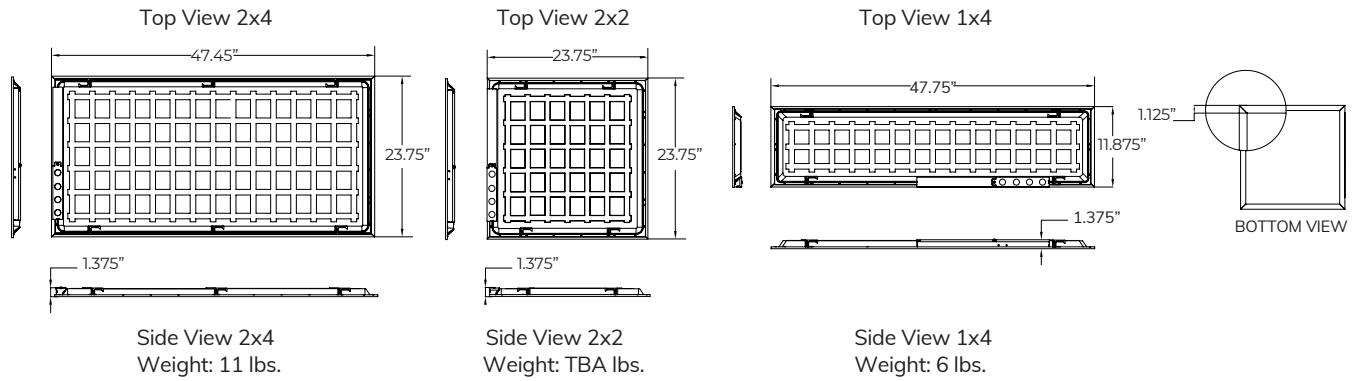

PRODUCT SPECIFICATIONS

Model	Item Number	Wattage	Lumens	LPW	Color Temperature	Dimming	Power
E1HPL1-H3040D-83550 1'x4' Panel	65160	30W 36W 40W selectable	3300 3960 4400 LM selectable	110	3500K 4000K 5000K adjustable	0-10V	120-347V
E1HPL2-H2130D-83550 2'x2' Panel	65161	21W 25W 30W selectable	2301 2750 3300 LM selectable	110	3500K 4000K 5000K adjustable	0-10V	120-347V
E1HPL4-H3645D-83550 2'x4' Panel	65163	36W 40W 45W selectable	3960 4400 4950 LM selectable	110	3500K 4000K 5000K adjustable	0-10V	120-347V



Field-selectable CCT and wattage control provides flexibility to installation and stocking

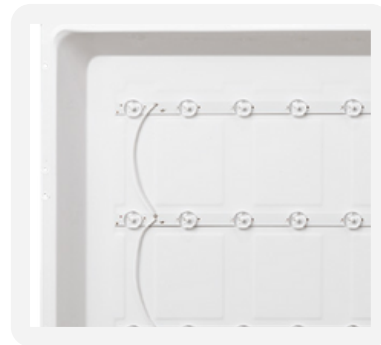

Vitality™ LED Technology that increases alertness and reduces fatigue in places with no sunlight.



Extruded aluminum lens frame with visually seamless corners



Integrated fold-out seismic hooks with suspension cable mounting hole